

Optimization of Network Reconfiguration in the ULP Way Halim Distribution System, Bandar Lampung City Considering the Use of Nonlinear Loads

1st Muhira Dzar Faraby

Department of Electrical Engineering
State Polytechnic of Ujung Pandang
Makassar, Indonesia
muhira_faraby@yahoo.com

2nd Sofyan Sofyan

Department of Electrical Engineering
State Polytechnic of Ujung Pandang
Makassar, Indonesia
sofyantato@poliupg.ac.id

3rd Ahmad Rosyid Idris

Department of Electrical Engineering
State Polytechnic of Ujung Pandang
Makassar, Indonesia
ahmadrosyid@poliupg.ac.id

5th Usman

Department of Electrical Engineering
State Polytechnic of Ujung Pandang
Makassar, Indonesia
usman.ose@poliupg.ac.id

5rd Andi Fitriati

Department of Mechatronic
Engineering
Polytechnic of Bosowa
Makassar, Indonesia
andi.fitriati@politeknikbosowa.ac.id

6th Isminarti

Department of Mechatronic
Engineering
Polytechnic of Bosowa
Makassar, Indonesia
isminarti@politeknikbosowa.ac.id

Abstract— Harmonic Distortion is a problem that is a challenge in itself in maintaining the quality of electric power due to the use of nonlinear loads. Network reconfiguration is considered capable of improving distribution system performance by operating a tie switch until an optimal configuration is obtained. This study aims to optimize network reconfiguration techniques to minimize total channel power losses and %THD_v using the Particle Swarm Optimization (PSO) method which was tested on the ULP Way Halim Electrical System, Bandar Lampung City 88 buses. The optimization results obtained a decrease in the total power loss of the channel by 64.75 kW or 79.51% and reduced the %THD_v value.

Keywords— Harmonic Distortion, Reconfiguration, tie switch, PSO, %THD_v

I. INTRODUCTION

The use of power electronic devices in industrial control system equipment, welding machines, fluorescent lamps and others is a nonlinear load category in the electrical load in the electric power distribution system. Nonlinear loads inject harmonic currents. This current can generate non-sine waves due to a wave distortion process known as harmonic distortion. Harmonic distortion values that exceed the allowable limits have a negative impact on the system in the form of heating, decreasing the insulating properties of materials to damage to the equipment used [1]-[2]. To review the spread of harmonic distortion in a radial distribution system, the Forward Backward Sweep (FBS) power flow method is used to determine the value of voltage level, current between channels and total channel power loss at fundamental frequency and Harmonic Load Flow (HLF) is used to determine %THD_v, %THD_i and line power loss in each harmonic order [3]-[5].

The radial distribution system is a distribution network topology that is widely used as a channel with low voltage levels, large current values, disturbance ranges with radial structures and high of power losses [6]-[7]. The current resistance and reactance of the feeder are the main factors that affect the value of the line power loss both in fundamental conditions and in each order of harmonics [8]. Network

reconfiguration is one of the optimization techniques that can be used which is considered effective in solving this problem because it does not use high investment costs [9]-[11].

The use of artificial intelligence-based optimization methods is widely used in solving complex optimization problems. To achieve better system conditions, an appropriate optimization method is needed so that an optimal solution is obtained [12]. Particle Swarm Optimization (PSO) is an optimization method that is considered capable of providing an optimal solution to an optimization problem. Last research, optimal network reconfiguration using PSO [13], biological cell optimization [14], ant colony and genetic algorithm [15] gives good results for increasing power quality to reducing harmonic distortion in the distribution system. This study aims to optimize network reconfiguration techniques to minimize total power losses and minimize %THD_v using the (PSO) method which will be tested on the ULP Way Halim 88 Electrical System for Bandar Lampung City buses.

II. MODELING SYSTEM

A. Standard Harmonic

% V_{THD} is the percentage of the total voltage that is distorted by harmonics against the fundamental frequency and % I_{THD} is the percentage of the total amount of current that is distorted by harmonics about the fundamental frequency [16]-[18]. The voltage harmonic standard used according to IEEE Std. 519-1992, p.85. for Voltage Harmonic Distortion in Table 1.

Table 1. Voltage Distortion Limit.

Bus Voltage at PCC	Individual Voltage Distortion I _{THD} (%)	Total Voltage Distortion V _{THD} (%)
69 kV and below	3.0	5.0
69,001 kV through 161 kV	1.5	2.5

B. Harmonic Load Flow Analysis

The matrix $[A]$ representing the relationship between the branch current and the bus injection current for the h^{th} harmonic sequence is obtained using the backward sweep algorithm. While the forward sweep method produces a matrix $[HA]$ which represents the relationship between the harmonic bus voltage and the injection current of the bus harmonics. harmonic power flow algorithm, n-bus radial distribution system is shown in the single line diagram in Figure 1.

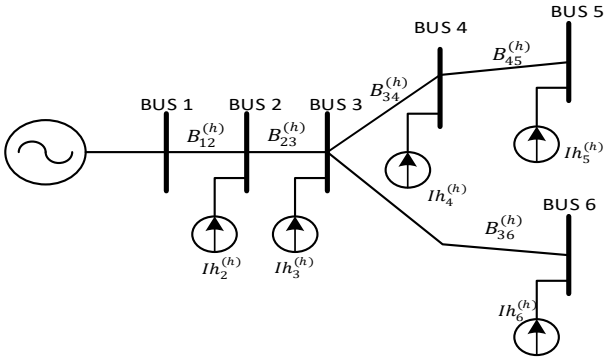

Figure 1. IEEE 6-bus injected with harmonic currents.

Bus 1 is assumed to be a generator and is considered a swing bus with 5 loads. The h -th harmonic current ($I_h^{(h)}$) contributed by the nonlinear load in Figure 1 can be expressed as follows:

$$[I_h^{(h)}] = [I_{h2}^{(h)} + I_{h3}^{(h)} + I_{h4}^{(h)} + I_{h5}^{(h)} + I_{h6}^{(h)}] \quad (1)$$

The FBS method is used here but considers the presence of harmonic distortion. Matrix $[A]$ represents the relationship between branch currents and bus injection for the order of harmonics obtained using the Backward Sweep Method. Matrix $[HA]$ represent the relationship between harmonic of voltage bus and harmonic of injection current bus obtained using the Forward Sweep Method.

The Backward Sweep method is used to get the current flowing from the $i - j$ branch in the following equation (2)-(3).

$$[B_{i-j}^{(h)}] = [A_{i-j}^{(h)}] * [I_{i-j}^{(h)}] \quad (2)$$

$$[A_{i-j}^{(h)}] = \begin{bmatrix} Ah_{i-j}^{(h)} \\ \cdot \\ \cdot \\ Ah_{i-j}^{(h)} \end{bmatrix} \quad (3)$$

matrix $[A_{i-j}^{(h)}]$ is coefficient vector for the presence of harmonic current flowing through the $i - j$ branch. Forward Sweep method is used to find harmonic voltage in each bus in the following equation (4)-(6);

$$[V_{i-j}^{(h)}] = [Z_{i-j}^{(h)}] * [B_{i-j}^{(h)}] \quad (4)$$

$$[V_j^{(h)}] = [V_j^{(h)}] - [V_{i-j}^{(h)}] \quad (5)$$

$$[V^{(h)}] = [HA^{(h)}] * [I^{(h)}] \quad (6)$$

If the iteration is less than or equal to the tolerance specified by ϵ then the value of the harmonic voltage on the bus can be calculated by the following equation;

$$|V_i^{(h),k+1} - V_i^{(h),k}| \leq \epsilon \quad (7)$$

Total active power losses of harmonic can be written with vector form as follows;

$$P_{Loss}^{(h)} = \sum_{i=1}^{br} P_{Loss_i}^{(h)} = \sum_{i=1}^{bt} \sum_{h=h_0}^{h_{max}} |B_i^{(h)}|^2 R_i^{(h)} \quad (8)$$

$$P_{Loss}^{(h)} = [R^{(h)}]^T * [A^{(h)}] * [I^{(h)}]^T \quad (9)$$

The voltage values of rms bus i (V_{rms_i}) and THDv in each bus can be calculated as follows;

$$V_{rms_i} = \sqrt{|V_i^{(1)}|^2 + \sum_{h=h_0}^{h_{max}} |V_i^{(h)}|^2} \quad (10)$$

$$THDv = \frac{\sqrt{\sum_{h=h_0}^{h_{max}} |V_i^{(h)}|^2}}{|V_i^{(1)}|^2} \quad (11)$$

C. Network Reconfiguration

Network reconfiguration is the rearrangement of the distribution network by operating the tie switch by opening or closing it to change the system configuration. In general, network reconfiguration is used to reduce power losses in the network and overcome overload. In addition, network reconfiguration operations can be performed to mitigate power quality problems and reduce the effects of harmonics on the distribution network [19].

Configuration changes are made while maintaining the shape of the distribution network and power supply to the load. Network reconfiguration is carried out using an algorithm to obtain the optimal switching pattern to achieve minimal power losses [20]. The algorithm works by reading data and doing load flow. Then open the tie switch and close a different tie switch to get the configuration. The operation is carried out until a predetermined objective function is achieved, such as the percentage of minimum power losses [21].

D. Particle Swarm Optimization

PSO is one of the evolutionary computational techniques, in which the population in PSO is based on a search algorithm and begins with a random population called a particle. In the PSO method, each individual is modeled as moving towards a space problem whose position is determined by the vector. Information from each individual is based on their own experience and knowledge from other individuals. The speed of each individual can be formulated as follows [15]-[17].

$$V_{id} = w V_{id} + C_1 r_1 + (P_{id} + X_{id}) + C_2 r_2 (P_{gd} - X_{id}) \quad (12)$$

$$X_{id} = X_{id} + V_{id} \quad (13)$$

III. METHODOLOGY

A. ULP Way Halim Distribution System, Lampung City

The ULP Way Halim distribution system in Lampung City has 4 feeders from 2 substations modeled to 88 buses.

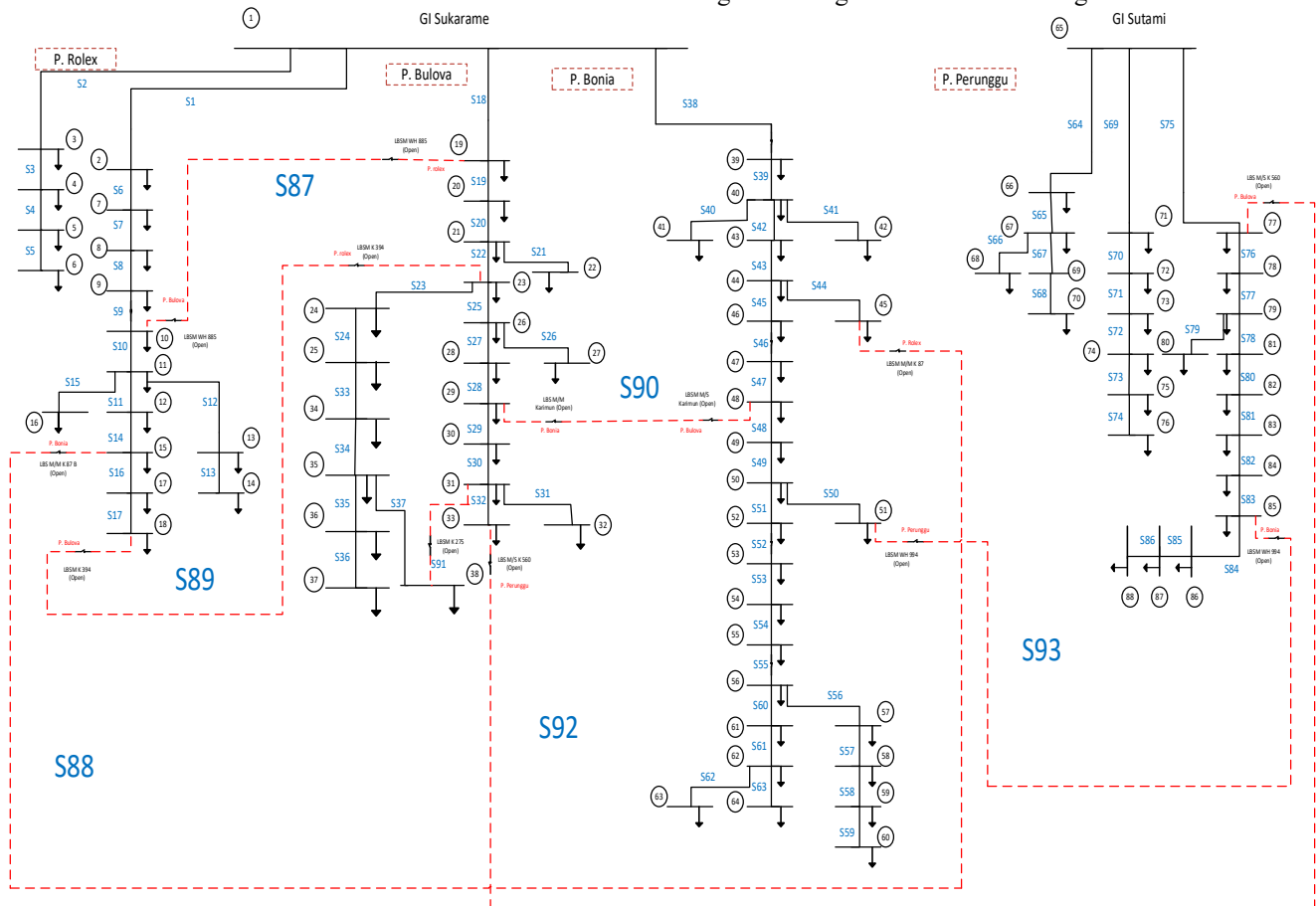

Figure 2. Single Line Diagram of the ULP Way Halim Distribution System, Bandar Lampung City [22].

B. Source of Harmonics

Variable Frequency Drive type nonlinear load used as a source of harmonics can inject harmonic currents placed on bus loads 2, 5, 12, 15, 17, 18, 19, 26, 27, 31, 32, 37, 42, 44, 51, 53, 54, 57, 60, 61, 62, 66, 69, 70, 73, 80, 83, 86, 87 and 88. The amount of injection current given from is shown in Table 2.

Table 2. Large harmonic current injection [23].

Orde	Mag (%)	Phase Angle
5 th	98	140
7 th	39.86	113
11 th	18.95	-158
13 th	8.79	-178
17 th	2.5	-94

C. Objective Function

- Minimum total line power loss

$$P_{Loss} = \sum_{i=1}^{nb} P_{Loss_i}^{(1)} + \sum_{i=1}^{nb} \sum_{h=h_o}^{h_{max}} P_{loss_i}^{(h)} \quad (11)$$

- Minimum %THDv

$$\%V_{THD,i} = \frac{V_{d,i}}{V_{rms,i}} * 100\% \quad (12)$$

The feeders are Bonia feeders, Rolex feeders, Bulova feeders at the Sukarame substation and Perunggu feeders at the Sutami substation. The existing substation is modeled as a Slack Bus while the feeder is modeled as a Load Bus. The single line diagram can be seen in Figure 2.

D. Constrain

- Bus Voltage Limit

$$V_{min}(0.95 pu) \leq V_{rms_i} \leq V_{max}(1.05 pu) \quad (13)$$

- Total Harmonic Distortion

$$THD_i(\%) \leq THD_{max} \quad (14)$$

- Network topology after network reconfiguration is still in radial condition.

E. Network Reconfiguration Techniques

In this study using existing switches and not creating new channels. Switches that connect between buses become objects to determine the most optimal combination [24]. There are seven search loops based on the determination of the tie switch and the channel to be reconfigured. The combination of existing switches is used to determine the search space in the optimization process. From the search loop that has been determined, the channel will be broken so that the new channel can be connected through the switch closing process (tie switch closed). Loop data on the system can be seen in table 3.

Table 3. System reconfiguration loop data.

Reconfiguration Loops	Switch
1	S1, S6, S7, S8, S9, S87
2	S16, S17, S19, S20, S22, S88
3	S25, S27, S28, S45, S46, S47, S89
4	S23, S24, S33, S34, S37, S29, S30, S90
5	S10, S11, S14, S42, S43, S44, S91
6	S32, S75, S92
7	S48, S49, S50, S80, S81, S82, S83, S93

F. Research Stages

The stages of the optimization process carried out using the PSO method can be seen in Figure 3.

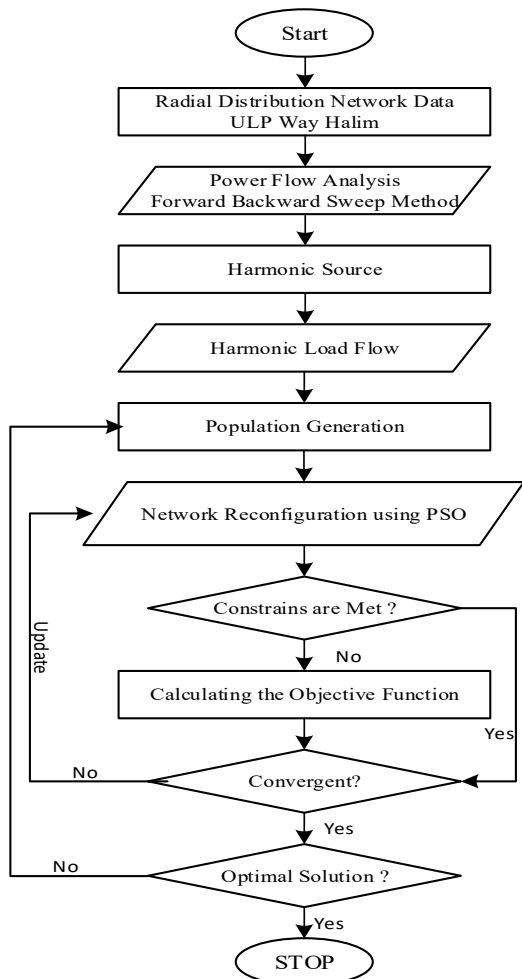

Figure 3. Research stages.

IV. RESULT AND DISCUSSIONS

The injection of harmonic currents from the use of nonlinear loads in the form of a variable frequency drive (VFD) generates the spread of harmonic distortion in the system making the %THDv value > 5%. The PSO method is used to determine a new network reconfiguration with the aim of minimizing the total loss of channel power and %THDv with population parameters = 100, and = 2. After testing the effect of harmonics on the system, steps are needed to obtain the optimal value of the system by reconfiguring. The reconfiguration process is carried out using the PSO optimization method on seven channels that have been determined based on table 4. The open channels are S1, S16, S25, S24, S10, S32, and S49. The results obtained are as follow in table 4.

Table 4. Comparison of data before and after reconfiguration using PSO.

Condition	Before Reconfiguration	After Reconfiguration
Open Switch	S87, S88, S89, S90, S91, S92 and S93	S1, S16, S25, S24, S10, S32, and S49
Total Active Power Losses (kW)	81.44	16.69
Total reactive power loss (kVAR)	341.36	74.46
Min voltage (pu)	0.98552	0.99557
Maximum voltage deviation(pu)	0.01448	0.00443
Maximum THD (%)	5.3313	1.7532

Based on table 4, it was found that after reconfiguring the network, it was found that there was a decrease in active power losses to 16.69 kw. In terms of voltage, it also gets better with a minimum voltage of 0.99557 pu which can be seen in Figure 4.

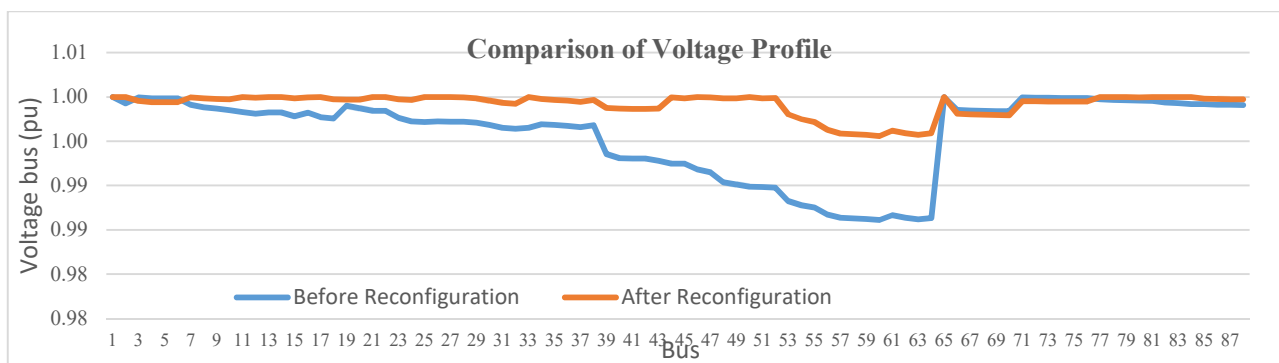

Figure 4. Comparison of bus voltages before and after optimization.

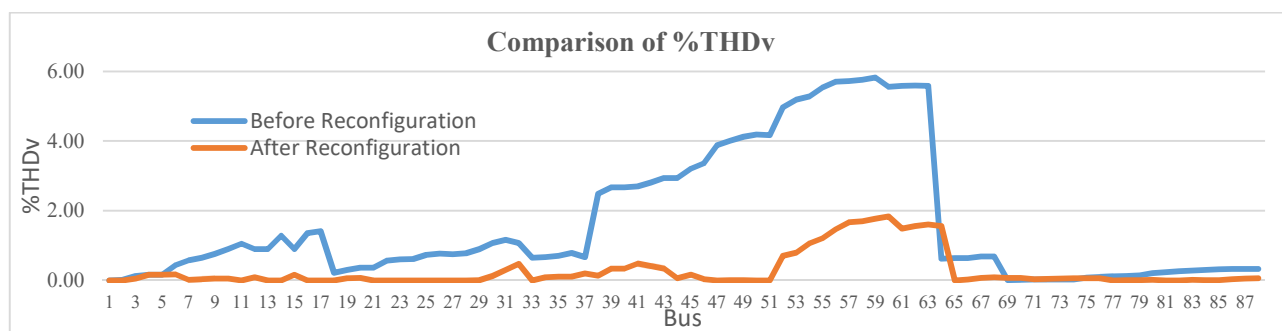

Figure 5. Comparison values of %THD_v before and after optimization.

In the comparison of the system's Total Harmonic Distortion chart, there is a decrease that makes the system no longer in a critical state beyond the predetermined standards. After reconfiguring the largest %THD_v, it only reached 1,754%.

Changing the current flow in the ULP Way Halim distribution system by reconfiguring the network can improve system performance in increasing efficiency in the form of increasing power quality in reducing the spread of harmonics. the spread of harmonics in the system cannot be mitigated by network reconfiguration techniques, but this optimization technique can improve system performance in fundamental conditions so that the %THD_v value improves in each order of harmonics.

V. CONCLUSION

The use of the Particle Swarm Optimization (MOPSO) method in optimizing network reconfiguration optimization techniques by considering the use of nonlinear loads which aims to minimize total channel power loss and minimize %THD_v gives optimal results. The result of the optimization is the determination of an open channel which is replaced by a tie switch with a network topology condition in a radial condition. There is an improvement in the bus voltage level, a decrease in the total loss of channel power loss by 64.75 kW or 79.51% and the %THD_v value is within the permitted limits.

ACKNOWLEDGMENT

Thank you very much to the Power System Simulation Laboratory (PSSL), Department of Electrical Engineering, ITS Surabaya for the research collaboration conducted with the Electrical Engineering Study Program, Makassar PNUP, Mechatronics and Electrical Engineering Study Program, Makassar Polibos and Electrical Engineering Department, Haluoleo University Kendari.

REFERENCES

- [1] M. D. Faraby, O. Penangsang and R. S. Wibowo, "Optimization of Placement and Sizing DG and Capacitor Bank with Network Reconfiguration Considering Non Linear Load on Radial Distribution Network," *2020 6th International Conference on Science and Technology (ICST)*, 2020, pp. 01-05, doi: 10.1109/ICST50505.2020.9732843..
- [2] M.D. Faraby, A. Fitriati, Christiono, Usman, A. Muchtar and A. Nur Putri, "Single Tuned Filter Planning to Mitigate Harmonic Polluted in Radial Distribution Network Using Particle Swarm Optimization," *2020 3rd International Seminar on Research of Information Technology and Intelligent Systems (ISRITI)*, 2020, pp. 418-422, doi: 10.1109/ISRITI51436.2020.9315518.
- [3] X. Liang, "Emerging Power Quality Challenges Due to Integration of Renewable Energy Sources," *IEEE Trans. Ind. Appl.*, vol. 53, no. 2, pp. 855-866, 2017, doi: 10.1109/TIA.2016.2626253
- [4] M.D. Faraby, M.D.C. Putra, O. Penangsang, R.S. Wibowo, D.F.U. Putra, Mukhlisin, A. Fitriati, "Analisis Penyebaran Harmonisa Pada Sistem Distribusi Radial Kota Bandar Lampung Menggunakan Metode *Forward Backward Sweep* dan *Harmonic Load Flow*," *Seminar Nasional Teknik Elektro dan Informatika (SNTEI 2021)*, pp. 80-85.
- [5] J. Radosavljevic, N. Arsic, M. Milovanovic, and A. Ktena, "Optimal Placement and Sizing of Renewable Distributed Generation Using Hybrid Metaheuristic Algorithm," *J. Mod. Power Syst. Clean Energy*, vol. 8, no. 3, pp. 499-510, 2020, doi: 10.35833/MPCE.2019.000259
- [6] J. Liu et al., "Modelling and analysis of radial distribution network with high penetration of renewable energy considering the time series characteristics," *IET Gener. Transm. Distrib.*, vol. 14, no. 14, pp. 2800-2809, 2020.
- [7] Z.O. Prabandaru, O. Penangsang & R.S. Wibowo, 2015, "Optimasi Penentuan Lokasi Kapasitor dan Rekonfigurasi untuk Meminimalkan Kerugian Daya Pada Jaringan Distribusi Radial Menggunakan *Genetic Algorithm*", Tesis Teknik Elektro ITS, Surabaya.
- [8] O. Amanifar, "Optimal distributed generation placement and sizing for loss and THD reduction and voltage profile improvement in distribution systems using particle swarm optimization and sensitivity analysis," *16th Electr. Power Distrib. Conf. EPDC 2011*, 2011.
- [9] M. D. Faraby and O. Penangsang, "Impact Optimal DG Placement Against Harmonic Distribution on Reconfiguration Distribution Network on Microgrid System," *IOP Conf. Ser. Mater. Sci. Eng.*, vol. 676, no. 1, 2019, doi: 10.1088/1757-899X/676/1/012007
- [10] M. D. Faraby and O. Penangsang, "A Study of Harmonic Spreading Against Distribution Network Reconfiguration in Passive Radial Distribution Systems," *Proc. - 2018 4th Int. Conf. Sci. Technol. ICST 2018*, vol. 1, no. 1, pp. 1-6, 2018, doi: 10.1109/ICSTC.2018.8528665.
- [11] E. Azad-Farsani, I. G. Sardou, and S. Abedini, "Distribution Network Reconfiguration based on LMP at DG connected busses using game theory and self adaptive FWA," *Energy*, vol. 215, p.119146, 2021.
- [12] F. Haz, G. A. Setia, Yusran, S. M. Said and H. R. Iskandar, "The Optimization of SVC Placement in Sulselbar Transmission System Using Inertia Weight Particle Swarm Optimization," *2019 2nd International Conference on High*

- Voltage Engineering and Power Systems (ICHVEPS)*, 2019, pp. 1-6, doi: 10.1109/ICHVEPS47643.2019.9011127.
- [13] L. J. S. Damião, W. G. Zvietcovich and F. R. A. C. Baracho, "Network reconfiguration in distribution systems to reduce harmonic distortion using Particle Swarm Optimization," *2018 IEEE PES Transmission & Distribution Conference and Exhibition - Latin America (T&D-LA)*, 2018, pp. 1-5, doi: 10.1109/TDC-LA.2018.8511683.
- [14] H. Azadi, B. Akbari and M. S. Sepasian, "Power Quality Enhancement in Distribution Systems Using Feeder Reconfiguration," *2018 Smart Grid Conference (SGC)*, 2018, pp. 1-6, doi: 10.1109/SGC.2018.8777854.
- [15] E. Nazerian, S. Gharebaghi and A. Safdarian, "Optimal distribution network reconfiguration considering power quality issues," *2017 Smart Grid Conference (SGC)*, 2017, pp. 1-6, doi: 10.1109/SGC.2017.8308877.
- [16] "IEEE Recommended Practices and Requirements for Harmonic Control in Electrical Power Systems," *IEEE Std 519-1992*, pp. 1–112, 1993, doi: 10.1109/IEEESTD.1993.114370.
- [17] J. Teng and C. Chang, "Backward/Forward Sweep-Based Harmonic Analysis Method for Distribution Systems," in *IEEE Transactions on Power Delivery*, vol. 22, no. 3, pp. 1665-1672, July 2007, doi: 10.1109/TPWRD.2007.899523.
- [18] Yunwei Ryan Li; Farzam Nejabatkhah; Hao Tian, "Overview of Power Quality in Microgrids," in *Smart Hybrid AC/DC Microgrids: Power Management, Energy Management, and Power Quality Control*, IEEE, 2023, pp.185-217, doi: 10.1002/9781119598411.ch7.
- [19] M. D. Faraby, O. Penangsang, R. S. Wibowo, and A. Sonita, "Improved Performance Network Reconfiguration in Coordinated Planning in Radial Distribution System Considering Harmonic Distortion," *Int. Rev. Model. Simulations*, vol. 14, no. 2, pp. 146, 2021, doi: 10.15866/iremos.v14i2.20472.
- [20] K. M. L. Prasanna, R. J. R. Kumar, A. Jain, and J. Somlal, "Optimal reconfiguration of radial distribution system having photovoltaic distributed generation with controlled voltage," *IEEE Int. Conf. Circuit, Power Comput. Technol. ICCPCT 2015*, no. November 2017, 2015, doi: 10.1109/ICPCT.2015.7159518.
- [21] L. Guo *et al.*, "Distribution Network Reconfiguration Algorithms: A Comparative Study," *2022 IEEE 5th International Conference on Electronics Technology (ICET)*, 2022, pp. 472-478, doi: 10.1109/ICET55676.2022.9824709.
- [22] PLN UID Lampung, "Study of Masterplan Electricity Bandar Lampung City," 2020, pp. 1-156
- [23] M. D. Faraby, A. Sonita and Nurhayati, "The Effect of Single Tuned Filter on Coordinated Planning in Increasing Power Quality in Radial Distribution System," *2021 3rd International Conference on Electrical, Control and Instrumentation Engineering (ICECIE)*, 2021, pp. 1-6, doi: 10.1109/ICECIE52348.2021.9664706.
- [24] A. M. Helmi, R. Carli, M. Dotoli and H. S. Ramadan, "Efficient and Sustainable Reconfiguration of Distribution Networks via Metaheuristic Optimization," in *IEEE Transactions on Automation Science and Engineering*, vol. 19, no. 1, pp. 82-98, Jan. 2022, doi: 10.1109/TASE.2021.30728